

RRCF ctg var. cu contragreutate
RRCF ctg with counterweight

RRCF ctg + AH var. cu contragreutate si
si amortizor hidraulic
RRCF ctg + AH with counterweight and
hydraulic damper

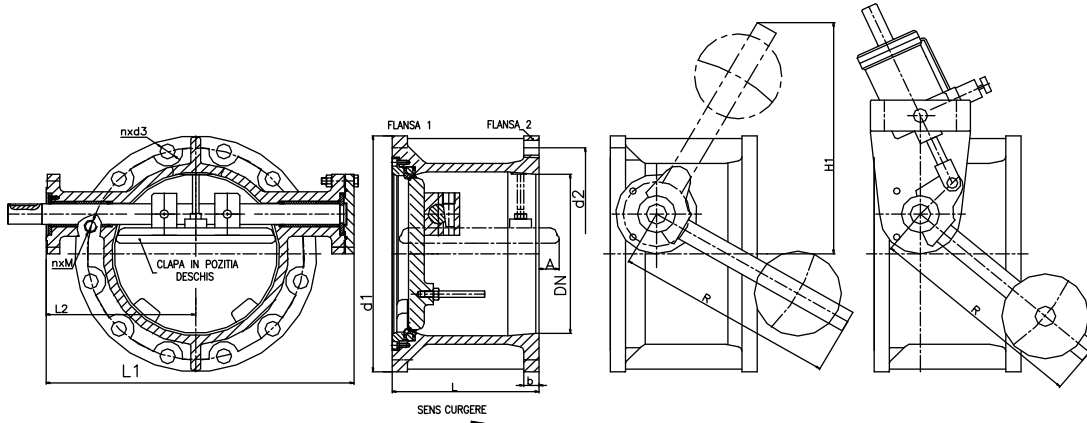

**CARACTERISTICI CONSTRUCTIVE SI FUNCTIONALE /
DESIGN CHARACTERISTICS:**

- lungime de constructie / overall length : - EN558/1 - S14;
- flanse de legatura / connection flanges :
- PN16 - EN1092-2; ISO 7005-2; DIN 2501
- gaurite / drilled PN10
- gaurite / drilled PN16
- variante de executie / design versions:
- cu ax liber / free shaft;
- cu contragreutate / with counterweight;
- cu contragreutate si amortizor hidraulic / with
counterweight and hydraulic damper;

- viteza maxima de curgere pentru lichide / max. flow speed for liquids: -4m/s
- timpul de inchidere pentru varianta cu amortizor hidraulic / closing time for the
design with hydraulic damper 3 ÷ 30 s
- etansare copr – capac: cauciuc / inox min. 11,5%Cr

**TEMPERATURA MAXIMA / TEMPERATURA MINIMA DE LUCRU – TS /
MAX. / MIN. WORKING TEMPERATURE – TS:**

- + 80° C / -10° C pentru garnituri NBR / for NBR gaskets;
- + 120° C / -10° C pentru garnituri EPDM / for EPDM gaskets;

NOTA: montajul in instalatie va respecta sensul unic de curgere marcat pe corp
NOTE : When mounting, observe the unique flow direction marked with arrow on
body;

POZ. ITEM	REPER PART NAME	MATERIAL / MATERIAL	
		TIP TYPE	SIMBOL SYMBOL
1	Corp / Body	fonta cenusie / cast iron fonta cu grafit nodular* ductile iron *	EN-GJL-250 EN-GJS-500-7
2	Clapa / Disc	otel carbon / carbon steel	OL37
3	Ax / Shaft	inox min11,5%Cr min 11.5%Cr stainless steel	20Cr130
4	Inel fixare / Lock ring	Zinc / zinc coated	OL37
5	Garnitura / Gasket	cauciuc + zinc rubber + zinc coated	NBR sau / or EPDM + OL37
6	Bolt / Bolt	nox min11,5%Cr min 11.5%Cr stainless steel	20Cr130
7	Capac / Bonnet	zinc / zinc coated	OL37
8	Opritor Retaining ring	zinc / zinc coated	OL37
9	Bucsa etansare Seat bush	bronz / bronze	CuSn5Zn5Pb5
10	Contragreutate Counterweight	fonta cenusie / cast iron	EN-GJL-250
11	Amortizor / Damper	-	-
-	Organe asamblare Bolting	otel carbon / carbon steel	-

* - la cerere / on request

(dimensiuni in mm / dimensions in mm)

DN	L	L1	L2	A	R	H1	Flanse de legatura / Connecting flanges						Masa neta Net weight ≈ [Kg]			
							d1	b	gaurite / drilled PN10		gaurite / drilled PN16		RRCF ctg	RRCF ctg + AH		
									d2	FLANSA FLANGE 1	FLANSA FLANGE 2	d2			FLANSA FLANGE 1	FLANSA FLANGE 2
										nxd3+nxM	nxd3				nxd3+nxM	nxd3
200*	230	463	220	18	250	175	340	20	295	6x23+2xM20	8x23	295	10x23+2xM20	12x23	85	95
250*	250	612	294	24	250	175	405	22	350	10x23+2xM20	12x23	355	10x27+2xM24	12x27	114	124
300	270	660	320	36	300	210	460	24,5	400	10x23+2xM20	12x23	410	10x27+2xM24	12x27	137	150
350*	290	703	340	58	350	250	520	26,5	460	12x23+4xM20	16x23	470	12x27+4xM24	16x27	192	205
400	310	682	330	87	400	283	580	28	515	12x28+4xM24	16x28	525	12x31+4xM27	16x31	225	240
500	350	872	420	140	500	355	715	31,5	620	16x28+4xM24	20x28	650	16x33+4xM30	20x33	350	365
600	390	1014	490	192	600	425	840	38	725	16x31+4xM27	20x31	770	16x36+4xM33	20x36	525	540
800	470	1204	577	290	800	565	1025	43	950	20x34+4xM30	24x34	950	20x39+4xM36	24x39	971	1000
1000	550	1500	705	420	1000	710	1255	50	1100	24x37+4xM33	28x37	1170	24x42+4xM39	28x42	1775	1825

* - la cerere / on request